

SEC:A-A

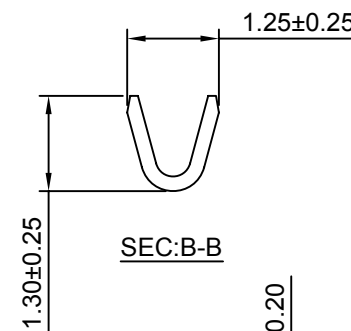

SEC:B-B

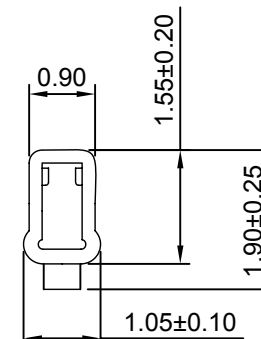

SEC:C-C

Ordering information & Specifications

Unit:mm

Part No	Wire Range	Insultion O.D.	Material	Finish	Qty/reel
A1501-TP	AWG#26-#32	1.10mm(max)	Phosphor Bronze	Tin over Nickel	10,000 PCS
A1501-GP	AWG#26-#32	1.10mm(max)	Phosphor Bronze	Gold over Nickel	10,000 PCS

Optional Gold plating available but MOQ requested



CHANGJIANG CONNECTORS CO.,LTD.

Unit	Scale	Sheet
mm	10:1	1 of 1

Title :

1.50mm PITCH

Draw BY:	Approved :
LIZQ	GONGYB

CRIMP TERMINAL

General Tolerance	
x.xx≤0.25	ANGLE±
x.xxx≤0.20	⊕
x.xxxx≤0.15	

A0	NEW RELEASE	2005.05.10
REV	DESCRIPTION	DATE

DRAW NO. : A1501-T	REV A0
--------------------	--------